

## Technical Datasheet

This diesel engine controller, type H100-840, is our updated version of the original H100 and is specifically designed to meet and exceed the requirements of standards EN12845 and LPC TB210 (including the 2022 requirements for data logging and pressure recording when used with a transducer)

The control system comprises of a colour graphic high resolution user display, LED indicators, actual discrete push buttons for all operations and a purpose designed interface board.

The colour graphic display shows both battery voltages, charger current, AC voltage, engine hours run, engine rpm, ambient temperature etc and all active alarms. Data logged events (500 stored) are also shown on the display.

The display and push buttons are used to modify parameters such as the number of flywheel teeth, delay start timer, stop timer, AC failure alarm timer etc. The display can also optionally show oil pressure, cooling water temperature, fuel level and water flow using a variety of input sensors. The controller is also capable of using a pressure transducer instead of a pressure switch for the pump start signal.

The battery chargers are constant current and constant voltage, switched mode type. They have an automatic boost facility and each charger has indication lights to show the present charging and battery status. The charger will pick up a fully discharged battery.

The controller includes a key mode switch to provide manual, off, and automatic modes. The controller is manufactured in a sheet steel enclosure which is weather proof to IP65 as standard. The standard controller is designed for both energised to stop and energised to run fuel operation. The controller has an engine heater output, and engine louver control as standard.

There is a WiFi embedded web access facility to enable the user to download log files and setting information.

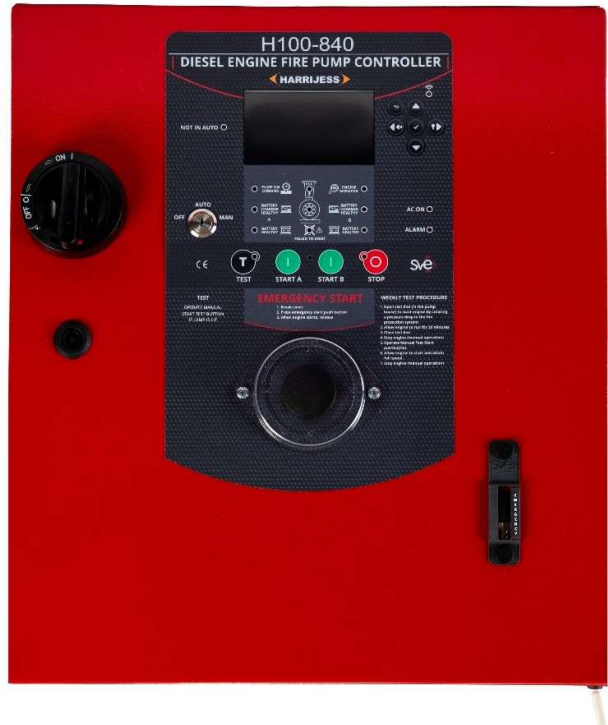

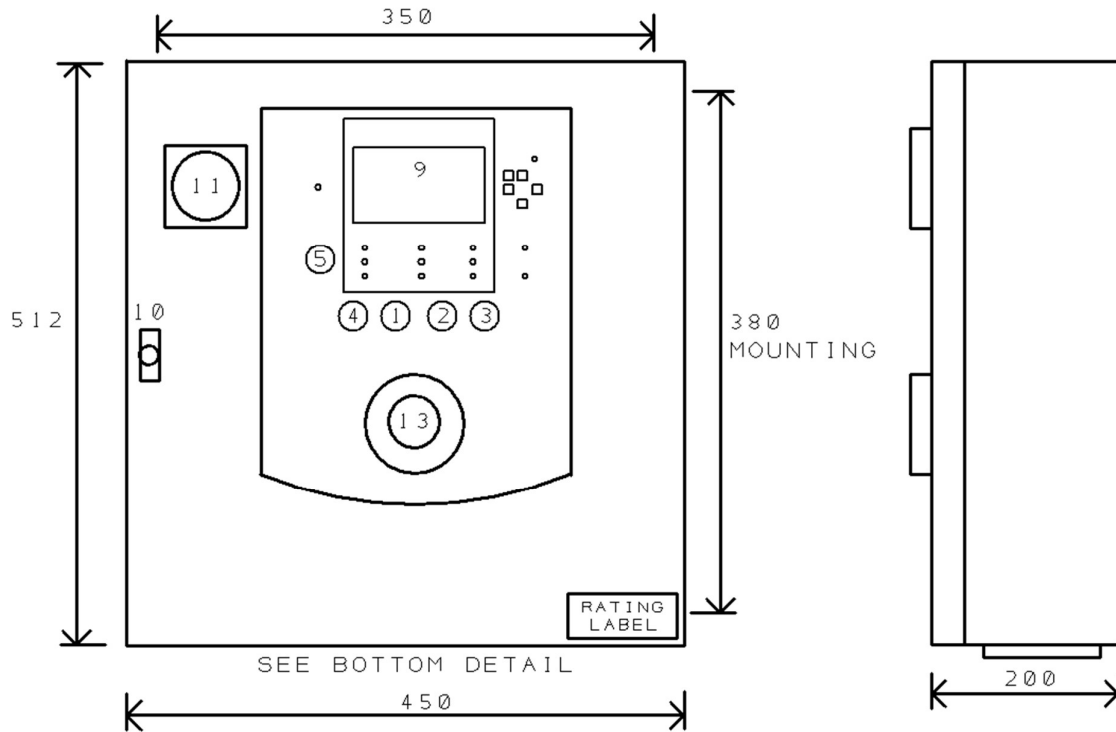

Alarms and Indications		
Mains voltage on	Auto mode	Pump/Engine running
Chargers Healthy	Manual mode	Alarm
Battery A & B Healthy	Off mode	Low oil Pressure
Battery A & B Overvoltage	Operate test start	High Water temperature
Alarms in service	Not in Auto	Low engine temperature
Pump on demand	Crank A & B	Low fuel level
Speed sensor fault	Engine Heater tripped	Failed to start
AC on	Not in Auto	

Volt free change over contacts (30v at 0.3A rated)		
Common Fault	AC Power on	Pump on demand
Not in Auto	Failed to start	Engine running x2

Push buttons / Switches		
Crank A	Navigation control arrows	Mode switch; Off, Man, Auto
Crank B	Emergency start	AC isolator, door interlocked
Stop	Alarm reset	Lamp test
Test start	Alarm mute	

